

**OPERATING CONTROLS**

(TYPICAL)

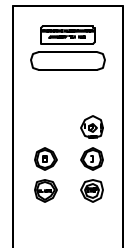
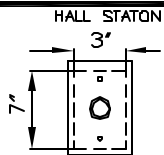

IN-CAR STATION

RAIL SUPPORT DETAIL

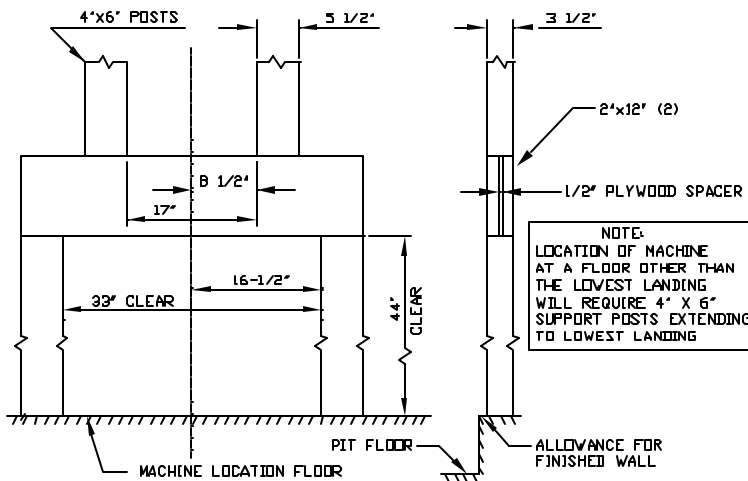

**DO NOT USE FOR CONSTRUCTION**  
FINAL CONSTRUCTION PRINT WILL BE PROVIDED

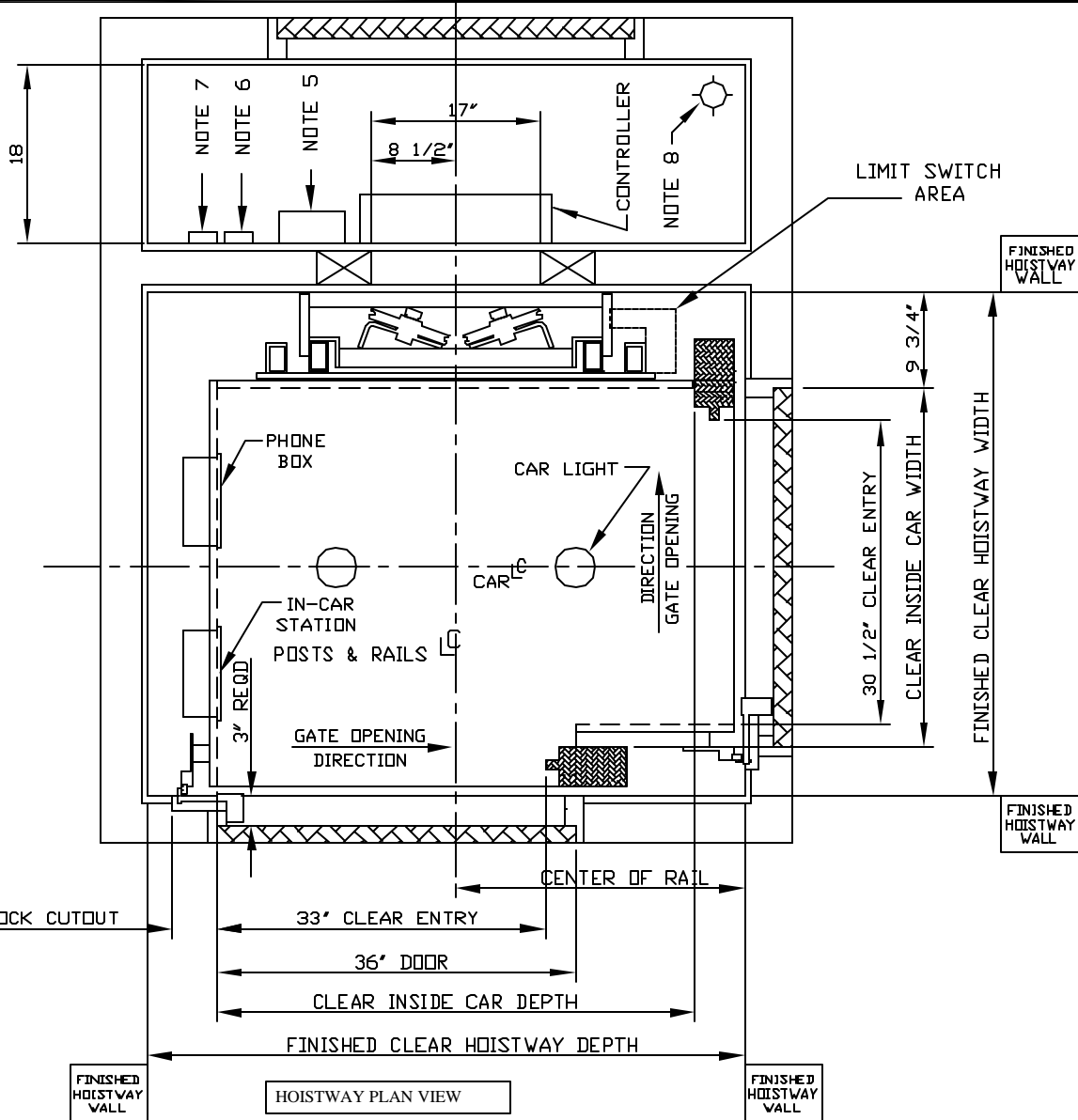

CAR SIZE	HOISTWAY WIDTH	HOISTWAY DEPTH	CENTER OF RAIL
36" W X 48" D	50 3/4"	60"	29"
36" W X 60" D	50 3/4"	72"	35"

**AMERICAN CRESCENT / MATOT**

PHONE: (601) 798-9392      PHONE: (708) 547-1888  
 FAX: (601) 798-9444      FAX: (708) 547-1608

DRAWING NO.

SCALE:

DB3RH99-WP

NO SCALE

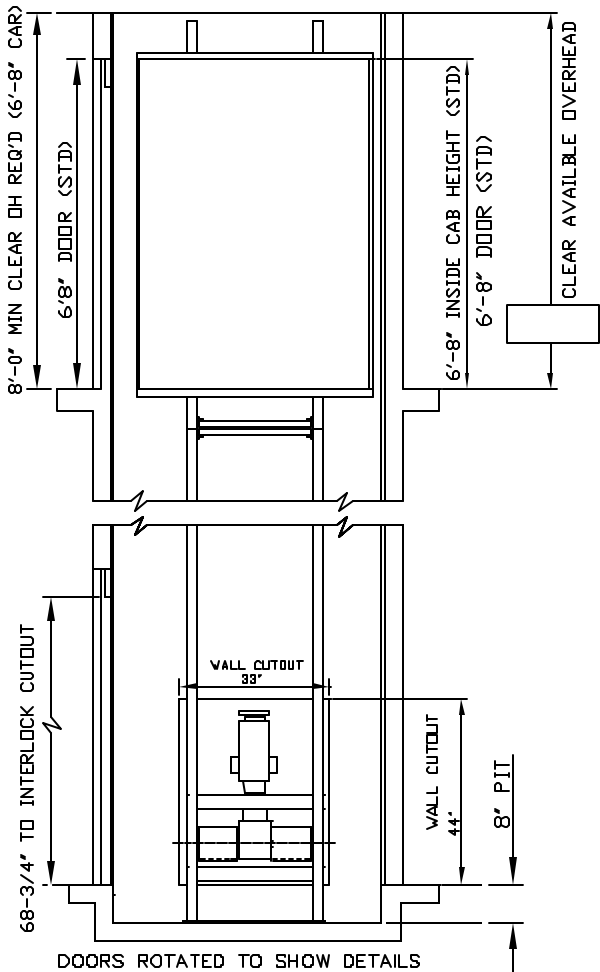

HOISTWAY ELEVATION VIEW

TRAVEL/DOOR LOCATIONS & SWINGS/FLOOR DESIGNATIONS

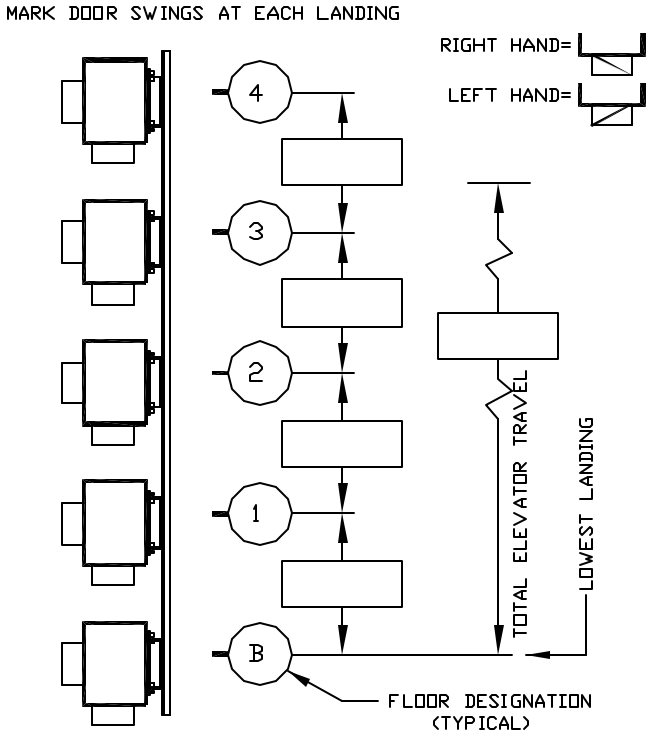

WORK DONE BY OTHERS

- (1) A suitable, legal, 2 hour rated, hoistway must be provided plumb and square within 1/16" for every 10' of travel. Hoistway must be free of all obstructions. Hoistway floor must be level.
- (2) Suitable, legal, 1-1/2' fire rated hoistway entrance doors and a machine access door must be provided. Entrance doors and associated framing to be provided and installed after the elevator is set in place. Door closers are recommended.
- (3) The front wall of the hoistway, for the entire width of the hoistway, at least 8'-0" high, is to be left open until the elevator car is installed.
- (4) Clearance between the hoistway doors and the car sill must not exceed 3" and the clearance between the hoistway door and the closed car gate must not exceed 5" per ANSI/ASME Elevator Code A17.1 - 1990. Check local codes provisions which may take precedence.
- (5) A fused, lockable, 3 pole, 240VAC, 30 amp, disconnect switch is to be provided.
- (6) A separate 120VAC, 15 amp, single phase power supply with a fused, lockable switch or circuit breaker must be provided and brought to the elevator controller for the car lights.
- (7) An outside telephone line must be provided and brought to the controller.
- (8) A suitable machine room, with a 120VAC convenience outlet, a light and a light switch must be provided. Machine room lighting must be maintained at a minimum of 10 foot-candles.
- (9) A pit of correct dimensions and suitable load bearing capacity must be provided on the lowest level as shown on the final drawings.
- (10) Structural load requirements: 1800lbs. vertical on pit floor, 50lbs. horizontal at each wall bracket.

MECHANICAL AND CAR SPECIFICATIONS

ESTIMATED MACHINE WEIGHT = 250 LBS	CAPACITY: 750 LBS
MAXIMUM CAR WEIGHT (INCLUDING CAR CAPACITY) = 1400 LBS	

JOB SPECIFICATIONS

MACHINE TYPE:	WINDING DRUM ADJACENT
MOTOR:	3 HP, 220 V, 1 PH, 60 HZ
AMPERAGE:	STARTING 78 RUNNING 15
CAB DESIGN	
ENTRANCE TRIM	
WALL FINISH	
GATE	
HANDRAIL	
FLOORING	
PHONE	
HOISTWAY DOORS	BY OTHERS
FIXTURE FINISH	
CAR CEILING	WHITE MELAMINE
MISC. CAR OPTIONS	

PROJECT \_\_\_\_\_ ELEVATOR CONTRACTOR \_\_\_\_\_

NO.	REVISIONS	DATE	BY
A			
B			
C			

**AMERICAN CRESCENT / MATOT**  
 PHONE: (601) 798-9392 PHONE: (708) 647-1888  
 FAX: (601) 798-9444 FAX: (708) 547-1608

DATE: 4/12/02	SCALE:
DRAWING NO. DB3RH99-WP	NO SCALE

THIS IS A TYPICAL DRAWING. CONTACT YOUR AMERICAN CRESCENT/MATOT SALES REPRESENTATIVE FOR PROJECT SPECIFIC DRAWINGS. DIMENSIONS ARE SUBJECT TO CHANGE WITHOUT NOTICE.